

STANDARD

WASTEWATER CONNECTION

JULY 2016

HUNTER WATER



TABLE OF CONTENTS

Document Information	5
Version History.....	5
Summary of Changes in this Version.....	5
Document Control	5
1 Purpose	6
2 Scope	6
3 SEWER	6
3.1 Methods of the Property Connection	6
3.2 System Types	7
3.2.1 Gravitational System	7
3.2.2 Gravitational System Configurations	7
3.2.3 Vacuum System	8
3.2.4 Sewerage Pumping Systems	8
3.2.5 Common Design and Inspection of Sewage Pump System.....	9
3.2.6 Hunter Water Pressure Sewerage Systems (HWPSS).....	9
3.2.7 Private Pressure Sewerage System (PPSS)	10
3.2.8 Common Effluent Pump System (CEP) – TSS-001 in Annexure.....	10
3.2.9 Individual Sewerage Pump Systems (ISPS) – TSS-002 in Annexure.....	11
3.3 Boundary Kits	12
3.3.1 Components of a Boundary Kit (See SCP-310 Annexure)	12
3.3.2 Privately Owned Pressure Sewerage System (PPSS)	13
3.4 Septicity and Flushing Responsibility	13
3.5 Retention of Existing Work	13
4 Non Standard Sewer Service	14
4.1 Introduction	14
4.2 Design and Inspection of Non-Standard Sewer Service.....	14
4.3 Maintenance of Non-Standard Sewer Services.....	15
4.4 Disconnection of a Non-Standard Sewer Service.....	15
5 Sewerage Flow Meters	15

5.1	Introduction	15
5.1.1	Flow Meters Installed in Gravitational Sewerage Systems	15
5.1.2	Flow Meters Installed in Pressure Sewerage Systems	16
5.1.3	Sewer Signage Requirements	16
5.1.4	Access and Maintenance Requirements.....	16
5.1.5	Accuracy and Integrity of Sewerage Flow Meter.....	16
6	Location Of The Point Of Connection To The Sewer.....	17
6.1	Introduction	17
6.2	Making a sewer connection	17
6.2.1	Gravity Sewer Connection	17
6.2.2	Sewer Pumping Systems Connection.....	18
6.3	Sewer Inspection Shafts at the Point of Connection.....	18
6.4	Boundary Trap Connections	19
6.4.1	Maintenance of Sewerage Inspection Shafts/Boundary Traps	19
6.5	Sanitary Drainage Sewage Overflow Relief Gully	19
6.6	Soffit Requirements	20
6.7	Sanitary Drainage Reflux Valves	21
6.8	Swimming Pool Backwash Discharge	21
6.9	Disconnection from Sewer.....	22
6.9.1	Sewer Point of Connection / Disconnection Requirements.....	22
6.10	Internal Disused Sanitary Drainage	22
6.11	Retention of Existing Work	22
6.12	Stormwater Discharge to Sewer – Prohibited.....	23
7	Trade Waste.....	23
7.1	Introduction	23
7.2	Liquid Trade Waste.....	23
7.3	Arrestors and Special Pits	24
7.4	Trade Waste Metering	24
7.5	Requirements to install a Reflux Valve	24

7.6	Location and Installation of Trade Waste Facilities	24
7.7	Trade Waste – Sewer Inspection Shaft	25
7.8	Trade Waste – Maintenance Responsibilities.....	25
8	Administration.....	26
8.1	Connecting to Hunter Water’s Services	26
8.1.1	How do I apply to connect or disconnect from Hunter Water’s Services?.	27
8.1.2	How do I find out what services are available to my property?	27
8.1.3	How do I connect or disconnect from Hunter Water’s wastewater services?	28
9	Definitions, Acronyms And Abbreviations	29
10	Appendix Documents	30

DOCUMENT INFORMATION

Version History

Version	Author	Sections Changed	Approved By	Date Approved
1.0	G Heaney	New Document	Chief Customer Services Officer	1 July 2016

Summary of Changes in this Version

Section Title	Section No.	Change Summary

Document Control

Document Owner	Group Manager Technical Services
Approvals	Chief Customer Service Officer
Related Documents	Services Guidelines
Associated Regulations / Standards	Independent Pricing Authority Regulatory Tribunal (IPART) NSW State Government and Coalition of Australia Governments (COAG) Plumbing Code of Australia Hunter Water Corporation Customer Contract 2011

1 PURPOSE

This Standard provides the minimum sewer connection requirements for properties located within Hunter Water's area of operations. All existing connections and new applications for connection will be required to meet the requirements of this Policy.

2 SCOPE

Connection to services is subject to any condition Hunter Water may lawfully determine to ensure the safe, reliable and financially viable supply of services to properties in the area of operations in accordance with the operating license.

This section sets out the general requirements to be followed for the work of plumbing and drainage connected to Hunter Water's sewerage infrastructure.

3 SEWER

Each land parcel shall have an individual connection point to Hunter Water's sewerage infrastructure. No private sanitary drainage pipeline or sewer rising main shall be extended to another Lot or land parcel without the prior written approval of Hunter Water.

In cases where a property is to be subdivided, and where existing buildings are to remain, each designated land parcel shall have an independent connection to Hunter Water's sewerage infrastructure.

Note: The sewerage service of any residential, community title, commercial or industrial development shall be separate and distinct from that of any other development. The only fittings to discharge into such service shall be those of the designated building and its fixtures to which the service is connected.

Customers must clear blockages in their private wastewater systems, identify and repair any defects that may occur, and maintain a clear and safe access to their point of connection to Hunter Water's sewerage system.

3.1 Methods of the Property Connection

In Hunter Water's area of operations sewerage servicing may be provided by a:

- Gravity Sewer Connection
- Vacuum Sewer Connection
- Sewerage Pumping System Connection

All connections to Hunter Water's sewerage system shall be formally approved before connection, to ensure correct and efficient system operation.

Hunter Water will not approve any wastewater connection if:

- There is no sewer service available in your area
- The available sewer main is not a connectable main
- Your connection will damage our assets
- The discharge wastewater is of a prohibited type
- The existing system has reached maximum capacity

3.2 System Types

3.2.1 Gravitational System

Hunter Water endeavours to provide an individual gravity sewer connection point to each separate lot. Hunter Water adopts the Water Services Association of Australia (WSAA) design manual for construction of gravitational sewers, which nominates the minimum depth of the sewer point of connection as normally installed at a depth that allows the most efficient drainage of the lot.

Before planning and construction of any structure, Hunter Water should be consulted to verify depths of the sewerage system connection point to ensure the proposed development can be serviced.

3.2.2 Gravitational System Configurations

See TSS-003; TSS-004; TSS-005 and TSS-006 in Annexure.

- a) Sewer main laid within property being served – The sewer point of connection is the arm of the junction located in Hunter Water’s sewer main within the customer’s property. The junction is sealed at the time of construction. Hunter Water owns the junction and adjacent sewer main. The customer is responsible for providing, connecting and maintaining the properties sanitary drainage connection to Hunter Water’s junction in accordance with the Plumbing Code of Australia & AS/NZS3500.2 Plumbing and Drainage.
- b) Sewer main laid outside property being served – The sewer point of connection is located at the end of a branch/sideline from the sewer main terminating within the customers’ property. Hunter Water may specify a “Y-junction” at the end of the sideline to which the property connection is to be made to the branch of the junction. This is to allow future maintenance or possible extension from the straight line section of the junction.

Hunter Water owns the branch/sideline and Y-junction. The customer is responsible for providing, connection and maintaining the sanitary drainage connection to Hunter Water’s sewer main in accordance with the Plumbing Code of Australia & AS/NZS3500.2 Plumbing and Drainage.

- c) Common Sanitary Drainage – A system of sanitary drainage pipe work that was an approved method of connecting a sewerage service to multiple dwellings in the early 1900’s. The properties at times had a common title or common family ownership. Alternatively, ownership was common to a particular employer who provided housing and employment packages.

While it is acceptable to own a property with an existing common sanitary drainage system, Hunter Water recommends, that at the time of resale, upgrading or replacement of plumbing works, enquiries should be made to Hunter Water regarding the possibility of providing individual sewer points of connection (direct sewer connection) for each property.

The owner must engage a licensed plumber / drainer to install and connect sanitary drainage to Hunter Water’s sewer connection point.

The re-use of common sanitary drainage does **NOT** comply with current Plumbing Regulations.

Hunter Water **DO NOT** own or maintain combined or joint private systems.

When drainage works are to be carried out on a common sanitary drain within the confines of an individual lot, all sanitary drainage works are to comply with the Plumbing Code of Australia and AS/NZS3500.2 Plumbing and Drainage. The works are deemed on-site drainage and all inspections for new and alternation works are under the regulatory requirements of NSW Fair Trading. This includes the common main sanitary drainage line.

3.2.3 Vacuum System

See SCP-317 in Annexure.

Hunter Water operates vacuum sewerage systems located in:

- Newcastle City Council area at Sandgate
- Lake Macquarie City Council area at Dora Creek

Only Hunter Water employees or persons authorised by Hunter Water are allowed access to the vacuum sewage collection chamber. The vacuum sewage collection chamber may be located within, or external of, the property boundary.

It is required that all improper function or damage to the vacuum sewage collection chamber is reported to Hunter Water immediately to ensure ongoing sewage disposal – 1300 657 657.

The connected sanitary drainage installation is to meet the requirements of AS/NZS3500.2 Plumbing and Drainage.

Note: Swimming pool water, filter backwash or garbage disposal units shall not discharge to a vacuum system without prior written approval from Hunter Water.

3.2.4 Sewerage Pumping Systems

Examples of these systems include:

- Hunter Water Pressure Sewerage System (HWPSS) – SCP-311
- Private Pressure Sewerage System (PPSS) – TSS-002
- Common Effluent Pumping System (CEP) – TSS-001
- Individual Sewerage Pumping Systems (ISPS) – TSS-002

All Sewerage Pumping Systems discharging to Hunter Water's sewerage system are required to have Hunter Water's approval prior to the commencement of works. Hunter Water requires designs of all sewerage pumping stations to be submitted for review and approval (minimum Hydraulic Assessment – Technical Review). The applicant/property owner must satisfy the requirements nominated in the review approval correspondence and any other requirements that Hunter Water convey in writing. Hunter Water in managing the sewerage system has strict requirements regarding system type, pumping pressure and pumping flow rate. Sewerage Pumping Systems that have been installed incorrectly without the specific approval of Hunter Water shall be replaced/reconfigured to satisfy Hunter Water's requirements at the property owner's expense.

Hunter Water specifies the installation and maintenance responsibilities regarding Sewerage Pumping System installation in Hunter Water Regulation 2015, Hunter Water Customer Contract and Hunter Water Services Connection Standards.

Hunter Water supports design practices that do not incorporate internal sewage pumping stations when gravity sewerage options are available.

See Annexure - Sewerage Pumping Systems Technical Specifications

Note: The sewerage pumping station design parameters shall minimise the septicity level in the sewerage holding well and relevant internal rising main. Septicity levels shall be compliant to Hunter Water's requirements.

The sewerage pumping system shall be installed in accordance with:

- AS/NZS3500.2 Plumbing and Drainage
- Hunter Water Requirements
- Local Council Requirements
- Building Code of Australia (BCA)
- Plumbing Code of Australia (PCA)

Where a private sewerage holding well is to be installed, the owner or owners' agent shall make application with the relevant Local Council to have the sewerage well approved and authorised. This is a requirement from NSW Health Department.

When a private sewage pump station is installed the installer shall supply relevant maintenance manuals and specifications of the system to the property owner for future reference.

Hunter Water recommends that the owners of a private sewerage pumping system engage an accredited service provider to monitor the ongoing performance and maintenance requirements of such systems.

3.2.5 Common Design and Inspection of Sewage Pump System

Hunter Water's design and inspection requirements for a Sewage Pump System include:

- Pump well configured with sloping bases (30° slope) towards pump pit
- Pump well control panel to incorporate audible and visible high level alarm
- Grinder / macerator pump – flow rates and pressure rating
- Pump run configuration to prevent septicity
- Rising main location approval from relevant property owner/s and/or Local Council (if applicable)
- Rising main material
- Rising main depth and appropriate backfill, marker tape and trace wire
- Ensure rising main connection to Hunter Water's sewerage system is compliant to Hunter Water's requirements.
- Hunter Water requires that only Hunter Water Accredited Designers shall be permitted to design pressure sewer systems for Hunter Water's wastewater networks.

3.2.6 Hunter Water Pressure Sewerage Systems (HWPSS)

See SCP-311 in Annexure.

This system incorporates a sewerage holding well and grinder/macerator pump that discharges wastewater at a designated flow rate to Hunter Water's sewer point of connection.

Owner's responsibility

- To provide a designated, protected electrical power circuit at a suitable location and ongoing power usage costs, and to maintain a compliant sanitary drainage system.

Hunter Water's responsibility

- Own and maintain the sewage well (up to the first incoming pipework joint to the well), pumping unit, pump control panel and pressure main up to and including the boundary kit for residential customers only.

3.2.7 Private Pressure Sewerage System (PPSS)

See TSS-002 in Annexure.

The Private Pressure Sewerage System (PPSS) incorporates a sewerage holding well and grinder/macerator pump that discharges wastewater at a designated flow rate to Hunter Water's sewer point of connection.

The design parameters of the PPSS system are exactly the same as HWPSS except for ownership and maintenance responsibilities.

Hunter Water only maintains from the test tee in the boundary kit to the sewerage rising main. This may be via a common or individual rising main to a Hunter Water receiving manhole. Benefits include smaller wells and minimal odour complaints.

Owner's responsibility

- Sewage well, grinder/macerator pump, maintenance, and maintain the internal rising main up to but not including the boundary kit.
- Providing the maintenance for electrical control panel, electrical power supply and ongoing power usage costs.
- To maintain a compliant sanitary drainage system. The owners engaged licenced plumber/drainier shall:
 - Ensure the selected pump is protected from overheating by thermal overload control
 - Ensure the pressure and flow rate meet Hunter Water's requirements.

Hunter Water responsibility

- Hunter Water pressure main, property branch line up to and including the property boundary kit/valve located immediately inside the property boundary.

3.2.8 Common Effluent Pump System (CEP) – TSS-001 in Annexure

A Common Effluent Pump System (CEP) incorporates a septic tank and holding well. Solids are retained in the septic tank and Hunter Water receives the pumped effluent wastewater from the holding well.

This system is normally configured with a connection point provided to each property from a common Hunter Water pressure main.

Note: New Common Effluent Pump Systems shall NOT be installed in areas outside of Hunter Water designated Common Effluent Rising Main areas.

Hunter Water acknowledges that there are existing CEP systems that discharge individually to Hunter Water's sewerage system via a sewer access chamber. These systems are considered "non-standard". Owner's responsibility and Hunter Water's responsibility for these systems are similar to Individual Sewerage Pumping Systems (ISPS).

Owner's Responsibility

- Septic tank and holding well, effluent pump, maintenance and internal rising main up to but not including the boundary kit/valve
- Providing the maintenance for electrical control panel, electrical power supply and ongoing power usage costs. Your engaged licenced plumber/drainier shall:
 - Install a pressure relief bypass valve on the rising main pipeline to help alleviate pump failure if for any reasons your system is unable to discharge effluent.
 - Ensure the selected pump is protected from overheating by thermal overload control
 - Prior to installation and commissioning of the pressure relief bypass valve determine the operating pressure of the sewer rising main. This determined sewer rising main operating pressure should be utilised when setting the initial relief valve pressure.
 - Ensure pressure and flow rates satisfy Hunter Water's requirements

Hunter Water's Responsibility

- Hunter Water pressure main and property branch line up to and including the boundary valve kit.

3.2.9 Individual Sewerage Pump Systems (ISPS) – TSS-002 in Annexure

These systems are installed when the topography of the customer's land or building design does not allow for a gravity sewer connection. The system comprises of 1 or 2 grinder/macerator pumps and a sewerage holding well that pumps via a private rising main into Hunter Water's gravitational sewer point of connection.

When the sewer point of connection is located inside your property boundary, this connection is a "standard" sewer connection under the Customer Contract.

When the sewer point of connection is located outside the property boundary and a rising main transverses private property or council road/roadside reserve, this connection will be considered "non-standard". For Non-standard Sewer Services the property owner is required to sign a contract agreement acknowledging and accepting the terms and conditions under which the sewer connection is permitted.

For ISPS technical requirements see Annexure.

The property owner is responsible for the operation of their individual sewage pumping system to ensure that the wastewater discharge to Hunter Water's sewage system is

compliant with Hunter Water's discharge quality levels (odour, septicity and corrosion levels).

Should the sewage pumping system discharge contravene Hunter Water's discharge quality levels, the property owner shall repair/rectify/reconfigure the system so that it complies.

Where a private sewage holding well is to be installed, the owner or owner's agent shall make application with the relevant Local Council to have the sewerage well approved and authorised. This is a requirement from the NSW Health Department and under the Local Government Act.

Owners Responsibilities

- Approval from Local Council
- Hydraulic Assessment Application to be submitted to Hunter Water
- Enter into a Non-Standard Sewer Agreement with Hunter Water
- Sewage wells, grinder pumps, maintenance and internal rising main up to but not including the receiving connection point
- Providing the maintenance for electrical control panel, electrical power supply and ongoing power usage costs

Hunter Water's Responsibilities

- The sewerage main and the deemed services connection point
- Hunter Water shall provide requirements for the approved and compatible pump types and specific flow rate discharges into Hunter Water's infrastructure. Hunter Water will specify septicity levels and other specific requirements on application.
- Hunter Water is required to carry out a site inspection to verify the pumps are as specified and the system complies with Hunter Water's requirements.

3.3 Boundary Kits

Pressure sewerage systems traditionally did not have a requirement to install boundary kits (diagnosis points). However, as of 1 July 2012 it became mandatory to install a boundary kit, due to continued maintenance requirements for systems by Hunter Water and the owner's service provider. The boundary kit must be located inside the property boundary at approximately 1m from the designated boundary line.

Should a fault occur, access and maintenance to the boundary kit is required by Hunter Water's maintenance personnel and your licenced plumber in order to diagnose if the problem is an internal fault or a Hunter Water sewerage system fault.

3.3.1 Components of a Boundary Kit (See SCP-310 Annexure)

All components fittings and valves shall be a minimum of 40mm and of a material approved by Hunter Water. This includes:

- Downstream isolating valve
- Union (downstream) for removal/replacement of components
- A plugged test tee (vertical) and capped test valve
- An approved non-return valve
- Upstream isolating valve
- Union (upstream) for removal/replacement of components

- An approved pit and riser to allow access and maintenance to the components

3.3.2 Privately Owned Pressure Sewerage System (PPSS)

See TSS-002 in Annexure

The boundary kit shall be installed by Hunter Water at the time of the pressure mains construction;

Hunter Water's Responsibility to Maintain

- Hunter Water will maintain up to the property side isolating valve of the boundary kit for residential customers only.

Owner's Responsibility to Maintain

- Possible vehicular damage and vandalism to the boundary kit and associated pipe work.

3.4 Septicity and Flushing Responsibility

Private sewerage pump systems often contribute to odour complaints from adjoining customers or from customer where the non-standard sewage system connects into Hunter Water's sewerage system.

The property owner is responsible for the satisfactory operation of the private sewerage pumping system. The private sewerage pumping system shall comply with the requirements of Local Government.

Legislation requires that an owner of a property shall not create unreasonable emission of odours from any land parcel. The emission shall not interfere with health, welfare, convenience or comfort of any person.

If Hunter Water determines an excessive odour is being emitted from an individual property, a rectification notice will be issued.

Rectification works may include but not be limited to:

- Adjust the pump activation mechanism to minimise retention and to ensure that no contents is stored for more than a four hour period.
- Benching the base of the wet well to reduce retention capacity and sludge build up
- Inclusion of time clocks and/or electronic level probe to activate the sewage pumping system to specific times per day
- Inclusion of "hours run meter/s" to monitor pump operation
- Install an appropriate flushing system

3.5 Retention of Existing Work

- Systems not currently connected to Hunter Water sewer main, may be connected only if the work consists of approved materials and permission is gained from Hunter Water. The licensee shall obtain Hunter Water requirements before connecting any pre-existing system. Hunter Water shall require a test to be carried out to verify soundness of the installation. Inspection of existing work shall be conducted by NSW Fair Trading.

4 NON STANDARD SEWER SERVICE

4.1 Introduction

A Non-Standard Sewer Service is installed when the topography of the customer's land or building design does not allow for a gravity sewerage connection. Systems may comprise of a:

- Common Effluent System (CEP – existing systems only – new connections no longer approved)
- Pressure Sewer System (“grinder/mutator” system)

While Hunter Water allows a connection to sewer mains that are not considered “standard” (Non Standard Sewer Service), the property owner is required to sign an agreement contract acknowledging and accepting the terms and conditions under which the sewer connection is permitted.

In accepting the Non-Standard Sewer Service terms and conditions, the property owner acknowledges that:

- The owner shall be entirely responsible for the provision and maintenance of any pipe or fitting extending beyond the sewer point of connection to the property and shall seek and obtain all necessary consents in writing for the location and placement of such pipe or fitting from the relevant authority or person/s
- The owner shall discharge only domestic sewage into Hunter Water's sewer unless otherwise authorised by Hunter Water in writing
- Hunter Water shall not be liable in respect to any loss or damage that the owner may suffer as a result of, or arising from any Non-Standard connection to Hunter Water's sewer mains
- If a sewer main becomes available that gives the owner a direct “standard” sewer connection point, the owner shall be required to connect to the alternative service
- All terms and conditions listed in the Non-Standard Sewer Service Agreement and technical specifications are met

The right to discharge sewage to Hunter Water's sewer main shall cease when the property owner ceases to be the registered proprietor of the property. The property owner shall advise the proposed purchaser of the terms of this agreement and the requirement to enter into a new agreement if connection to Hunter Water's sewer system is to continue.

Hunter Water specifies the installation and maintenance responsibilities regarding Non-Standard Sewer Service installation in Hunter Water Regulation 2015, Hunter Water Customer Contract, Trade Waste Water Policy and related Trade Waste Water Standards and Hunter Water's Services Connection Standard.

Refer to Annexure for Non-Standard Sewer Technical Specifications.

4.2 Design and Inspection of Non-Standard Sewer Service

Hunter Water's design and inspection requirements for a Non-Standard Sewer Service include:

- Pump well configured with sloping base (30° slope) towards pump pit
- Pump well control panel to incorporate audible and visible high level alarm

- Grinder / macerator pump – flow rates and pressure rating
- Pump run configuration to prevent septicity
- Rising main location approval from relevant property owner/s and/or Local Council
- Rising main material
- Rising main depth and appropriate backfill, marker tape and trace wire

Ensure rising main connection to Hunter Water’s sewerage system is compliant to Hunter Water’s requirements.

4.3 Maintenance of Non-Standard Sewer Services

The property owner/s is responsible for all maintenance costs of a Non-Standard Sewer Service.

4.4 Disconnection of a Non-Standard Sewer Service

Hunter Water requires an application for the disconnection of a Non-Standard Sewer Service. This application will generate an inspection to confirm compliant disconnection from Hunter Water’s sewerage system.

Should the Non-Standard Sewer Service disconnection be a part of a joint Non-Standard Sewer Service, it is a requirement that all other joint service parties be formally notified by the disconnecting party so that ongoing maintenance responsibilities of the Non-Standard Sewer Service can be confirmed.

5 SEWERAGE FLOW METERS

5.1 Introduction

Certain developments may introduce water from an alternative water supply that is designed to discharge into plumbing fixtures and then transfer as wastewater to Hunter Water’s sewerage system.

Hunter Water’s review of the design may direct that a sewage flow meter shall be installed to the sanitary drainage or pressure pumping systems to accurately measure the volume of sewage discharge that enters Hunter Water’s infrastructure.

The sewerage flow meter shall be of a type stipulated in a “Letter of Requirements” from Hunter Water and will be procured, installed and maintained by the customer.

5.1.1 Flow Meters Installed in Gravitational Sewerage Systems

Gravitational sewerage system flow meters shall be installed at either the point of connection to Hunter Water’s sewerage infrastructure or as otherwise directed by Hunter Water.

The property owner is responsible for providing a “fit for purpose” access chamber and a permanent 240 Volt power source to service the sewer meter. The provision of the sewer access chamber and power supply shall be installed to the designed requirements as stipulated by Hunter Water.

See Annexure for Technical Requirements for the installation of sewage flow meters.

5.1.2 Flow Meters Installed in Pressure Sewerage Systems

The pressure sewerage flow meter shall be installed above ground unless otherwise approved by Hunter Water. The flow meter shall be installed within the property boundaries and as close as practicable to Hunter Water's Sewerage connection point unless otherwise directed by Hunter Water.

The meters digital display and control panel – including any power/data requirements – shall be installed adjacent to the properties water meter/s or as otherwise directed by Hunter Water.

The property owner is responsible for providing “fit for purpose” access chamber (if a flow meter is to be installed below ground) and a permanent 240 Volt power source to service the sewage meter. The provision of access chamber and power supply shall be installed to the design requirements as stipulated by Hunter Water.

Flow meters installed above ground shall be protected from mechanical damage and vandalism; the owner is responsible to provide protective barriers to the requirements of Hunter Water.

See Annexure for Technical Requirements for the installation of sewage flow meters.

Note: Sewage flow meters have an electrical control panel. The panel shall be located in a position as directed by Hunter Water.

5.1.3 Sewer Signage Requirements

Signage on the sewage flow meter arrangements is required at the following locations:

- Sewage flow meter location – markers to identify inlet/outlet
- Sewage flow meter display location
- Source of sewage discharge via the flow meter
- Provide a block plan, A3 minimum size fixed adjacent the meter display. The plan shall be water and fade resistant and show structures that drain to and are discharged from the sewage well

5.1.4 Access and Maintenance Requirements

The property owner shall provide unlimited access for Hunter Water to routinely read the flow meter for billing purposes. The sewage flow meter owner is responsible for ongoing meter maintenance and meter calibration. Access and maintenance requirements are referenced in the Hunter Water Act and the Customer Contract.

If a flow meter becomes un-operational, Hunter Water may average the wastewater discharge from previous metering data (as detailed in the Customer Contract) to determine a sewer charge.

5.1.5 Accuracy and Integrity of Sewerage Flow Meter

Flow meters shall be of a type approved and certified “fit for purpose” by Hunter Water prior to installation. The flow meter shall be tested and certified by an accredited technician after installation and prior to discharging to Hunter Water's wastewater system.

Certification of sewage flow meter shall be submitted to Hunter Water on commissioning and annually thereafter.

The sewage flow meters shall comply with the requirements of the Australian Measurement Act (water meters) for operation and accuracy.

6 LOCATION OF THE POINT OF CONNECTION TO THE SEWER

6.1 Introduction

Point of Connection to the Sewer

- For gravity sewerage systems; this is the recorded end of the sewer pipe owned by Hunter Water to service the property when the sewerage system was installed.
- Where the sewer main is located within the property to be connected, this is usually the junction arm on the sewer main
- Where the sewer main is not located within the property to be connected, this is usually the end of the branch line (sideline)
- For sewage pumping systems the property service connection is the boundary kit/valve
- For vacuum systems this is the inlet point to the main (similar to the gravity sewerage system) that feeds into the vacuum pot

Hunter Water's ownership and maintenance responsibility is restricted to the sewer main and the joint immediately attached to Hunter Water asset (sewer point of connection).

All upstream pipework and fittings above the point of connection are the responsibility of the property owner.

See TSS-003 in Annexure for Sewer Point of Connection for New Works – as per WSAA Guidelines.

6.2 Making a sewer connection

6.2.1 Gravity Sewer Connection

The property owners engaged licenced plumber / drainer is responsible for locating the point of connection to the sewer. This involves:

- Obtaining a plan from Hunter Water showing the approximate depth and location of the sewer point of connection
- Excavating to the nominated location of the sewer point of connection – “staged” hand excavation and “probing” is required to prevent damage to sewer point of connection
- Where the sewer point of connection is unable to be located, the Licensee shall excavate at least one metre either side and/or one metre below the indicated position
- **If the point of connection cannot be located, the Licensee shall contact Hunter Water immediately for further directions**

NOTE: Hunter Water is not liable and accepts no responsibility or gives any guarantee or assurance for the currency, accuracy or comprehensibility of any information, plans or diagrams provided for sewer connection

- Proposed developments that have basements or “cut and fill” type construction included in the scope of works shall seek verification and approval from Hunter Water prior to commencement of any works
- Historically the location of the sewer point of connection in most circumstances is provided at the lowest point of the land parcel to adequately drain the proposed development / construction.

Hunter Water continues to follow sewer design guidelines where the sewer point of connection location is at a maximum depth of 1.8 metres. However, in some land parcels, the topography of the property requires the sewer point of connection to be at a greater depth.

In cases, where the depth of the sewer point of connection for new works is determined to be deeper than 1.8 metres, Hunter Water should be contacted for further directions.

6.2.2 Sewer Pumping Systems Connection

6.2.2.1 Private Pressure System (PPSS) and Common Effluent Pumping System (CEP)

Hunter Water shall be contacted to confirm the properties sewer connection point and type of pump system. The property owners are to engage a licenced plumber/drainier who is responsible for locating the point of connection to sewer. The customer’s connection point is typically just inside the property boundary and, depending on the system design, will generally consist of a small box housing the control valve/s.

6.2.2.2 Individual Sewerage Pumping Systems (ISPS)

The property owners are to engage a licenced plumber/drainier who is responsible for locating the point of connection to the sewer. The customer connection point may be inside or outside the property boundary. When the connection point is inside the property boundary, the ISPS is connected to the internal sanitary drainage or sewer inspection shaft. A Hydraulic Technical Assessment is required to be submitted to Hunter Water to determine specific requirements for the installation.

When the connection point is outside the property boundary, an application to Hunter Water requesting approval for connection is required prior to the commencement of any works. If successful, Hunter Water’s approval will nominate the approved connection point location and specific requirements. A Hydraulic Technical Assessment is required to be submitted to Hunter Water to determine specific requirements for the installation.

This connection outside the property boundary is considered Non-Standard, and as such shall require a formal agreement.

6.3 Sewer Inspection Shafts at the Point of Connection

Hunter Water requires that sewer inspection shafts/boundary traps be installed and located to the following requirements:

- The Building Code of Australia
- The Plumbing Code of Australia inclusive with NSW Amendments
- Australian Standard AS/NZS3500.2 Plumbing and Drainage

See TSS-005 in Annexure for Typical Non-Boundary Trap (Deep Connection) Inspection Shaft Connection for Single Residential Dwelling.

See TSS-005 in Annexure for Typical Non-Boundary Trap (Shallow Connection) Inspection Shaft Connection for Single Residential Dwelling

See SCP-317 in Annexure for Inspection Shaft Connection to Vacuum System.

See TSS-006 for Typical Boundary Trap Connections for Single Residential Dwelling.

Note: The Licensee shall check the “soffit” measurement in respect to the requirement to install a reflux valve (Soffit Requirements see Section 6.6)

6.4 Boundary Trap Connections

Hunter Water has specific requirements for connection to sewer which may require the installation of a boundary trap connection.

Hunter Water shall be consulted for:

- Connections to sewerage mains that are greater than or equal to 300mm
- Properties connected to a sewer main directly affected by a pumping or rising main, shall incorporate a boundary trap and a minimum of 100mm in-duct vent
- Historical boundary trap areas
- Where it is a Trade Waste requirement to discharge to sewer via a boundary trap
- Where a Hydraulic Assessment review has directed the installation of a boundary trap

Note: When replacing a shaft in a boundary trap area the sewer shaft must consist of an approved boundary trap and induct vent. The inspection opening immediately downstream of the boundary trap is recommended to be extended to finished surface level and terminated with an air tight removable lid for maintenance purposes.

6.4.1 Maintenance of Sewerage Inspection Shafts/Boundary Traps

The sewer inspection shaft is installed by the licenced plumber/drainer engaged by the property owner to carry out the works on the sanitary drainage connection of the development.

The sewer inspection shaft is part of the private sanitary drainage system and therefore providing access to the sewer inspection shaft, and all maintenance is the responsibility of the property owner.

Hunter Water requires access to property sewer inspection shafts to conduct inspection and maintenance on the sewer main branch. Clear safe access is to be made available by the property owner for this task. If sewer shaft installation and access are not compliant with Hunter Water Service Connection requirements, Hunter Water may be unable to carry out a diagnosis on behalf of the property owner to determine responsibility.

6.5 Sanitary Drainage Sewage Overflow Relief Gully

In accordance with the requirements of the Building Code of Australia, Plumbing Code of Australia and AS/NZS3500.2 Plumbing and Drainage, Hunter Water require that one specified sewer overflow relief gully is installed on each individual designated lot and deposited plan land parcel.

The overflow relief gully shall:

- Be strategically placed to provide a minimum of 150mm difference in height between all internal fixtures (floor wastes), and the spill level of the overflow relief gully
- Incorporate an unobstructed loose grating which allows free relief
- **NOT** allow the ingress of surface/storm water. Sewage overflow gullies installed on new development shall be specifically designed so as to prevent surface/storm water ingress.

6.6 Soffit Requirements

Soffit requirements shall be as follows:

- A) Between the soffit of the sewer main and the spill level of the Overflow Relief Gully (ORG), there shall be a minimum height of 1200mm
- B) The height of 1200mm may be reduced to 900mm where:

The number of properties connected upstream of the subject property does not exceed, or has the potential to exceed 10, or equivalent fixture unit loading, eg. 30 fixture units per property. The number of upstream properties can be obtained by contacting Hunter Water Plumbing Technical Services on 1300 657 657.

- C) Where minimum soffit requirements cannot be achieved, fixtures shall be connected to sewer by means of a reflux valve installed in accordance with The Plumbing Code of Australia and AS/NZS3500.2.
- D) Prior to the installation of the reflux valve, Hunter Water must be notified of the installation and property details by contacting Hunter Water Contact Centre on 1300 657 657.
- E) Only fixtures or whole properties that cannot drain by means of gravity sanitary drainage shall be pumped via a private well and grinder pump system. A minimum of a Hydraulic Technical Assessment shall be submitted to Hunter Water for review in these cases. The installation shall be installed to AS/NZS3500.2 in conjunction with Hunter Water's hydraulic review letter and technical specifications.

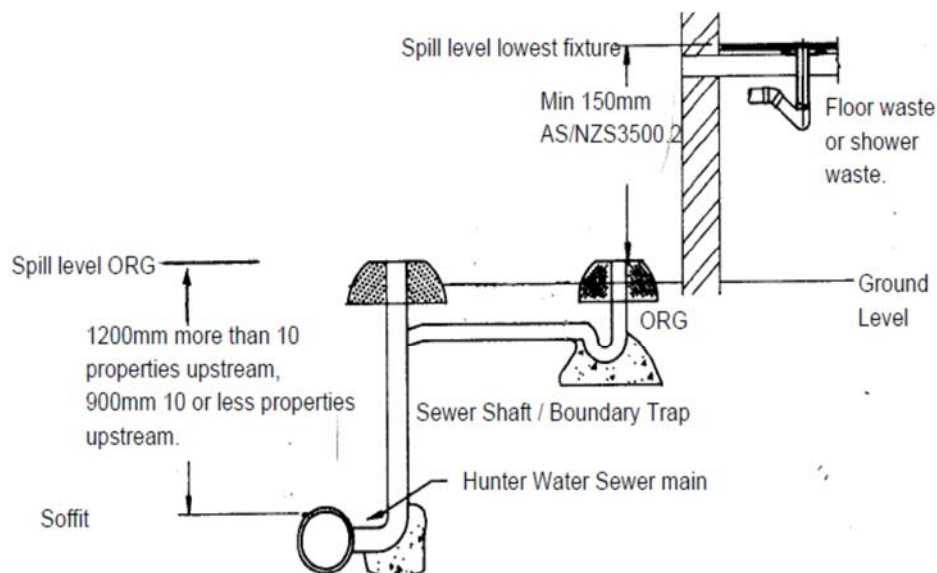

SOFFIT REQUIREMENTS HUNTER WATER

6.7 Sanitary Drainage Reflux Valves

Sewer reflux valves are installed to prevent potential internal sewage overflow to properties that have plumbing fixtures installed that may be influenced by sewerage overflow – through sanitary drainage design or the topography on the lot. It is the property owner's responsibility to engage a licenced plumber to install and maintain a sewer reflux valve as per manufacturer's specification.

In Hunter Water's area of operations the connection to gravity mains 300mm and greater is prohibited unless a reflux valve is installed directly at the point of connection.

The reflux valve shall be configured to prevent "floating" of the "flap valve assembly" in surcharge conditions (reflux valve extension handle shall be terminated 2-3mm under the access lid or as per manufacturer's specifications).

The installation of a reflux valve is generically due to the drainage requirements as detailed in AS/NZS3500.2 Plumbing and Drainage (overflow relief gully compliance) not being met.

Hunter Water shall not be responsible for sewage overflow in properties as a result of failure of the reflux valve (ie failure to operate).

Sanitary drainage reflux valves shall be approved and installed to the requirements of the Plumbing Code of Australia with NSW Amendments and AS/NZS3500.2 Plumbing and Drainage.

Hunter Water requires all new underground trade waste pre-treatment facilities that discharge wastewater to Hunter Water sewerage system, to install a sanitary drainage reflux valve to the outlet of the pre-treatment facility. This is to prevent sewage overflow entering the facility.

Hunter Water recommends reflux valves have signage clearly identifying the valve and advising of maintenance required.

6.8 Swimming Pool Backwash Discharge

In Hunter Water's area of operation residential swimming pool backwash waste shall only be connected to Hunter Water's sewerage infrastructure by a designated sanitary drainage fixture trap and air gap method of connection. The discharge pipe (sized – maximum 50mm) shall not discharge at a flow rate greater than one litre per second. The discharge of swimming pool backwash water shall not be carried out during rain periods.

A licenced person shall carry out all work in relation to a residential swimming pool backwash wastewater connection to the sanitary drainage system. The standard connection practice is by means of extending the backwash delivery pipe to an existing overflow gully or to a specifically installed new overflow gully. See TSS-007 in Annexure. The overflow relief gully grating must not be obstructed from allowing free overflow by the positioning of the swimming pool backwash discharge pipe.

Direct connection to the sewerage system or the sanitary drainage system of the property is prohibited. Residential swimming pool backwash discharge to sewer is prohibited in:

- Vacuum sewer system areas

- All pressure sewer system areas

Commercial, industrial and recreational properties shall apply individually for swimming pool backwash connections to Hunter Water's sewerage system.

6.9 Disconnection from Sewer

Where a property's sewer service has become redundant, or is not to be redeveloped and becomes disused, it shall be disconnected as required by Hunter Water at the property owners expense.

Disused sewer services are to be sealed off at the point of connection using approved materials in the accordance with AS/NZS3500.2 Plumbing and Drainage and Hunter Water requirements below.

Criteria for the sewer point of connection have changed over time. Existing points of connection may be at depths greater than current accepted depths. Under these circumstances it remains the property owner's responsibility to seal off the disused sewer service at the point of connection irrespective of the depth.

Sealing a sewer service at the inspection shaft is not allowed.

Hunter Water requires a **mandatory disconnection inspection** with appropriate fees paid.

6.9.1 Sewer Point of Connection / Disconnection Requirements

See TSS-004 in Annexure

Provide a 150mm PVC adapter and approved sealed screwed PVC cap on the private sanitary drainage line, upstream of Hunter Water's point of connection. This configuration allows potential future sewer connection possible with minimal impact to Hunter Water's sewer infrastructure.

The priority in this process is to maintain the integrity of Hunter Water's sewer point of connection and sewer main infrastructure.

Damage to Hunter Water's infrastructure shall be reported to Hunter Water as soon as possible and repairs will be at the responsible persons (licenced plumber/drainer) expense.

6.10 Internal Disused Sanitary Drainage

Internal disused sanitary drainage is to be disconnected to the requirements of AS/NZS3500.2 Plumbing and Drainage. Contact NSW Fair Trading for inspection requirements.

6.11 Retention of Existing Work

Systems not currently connected to Hunter Water sewer main, may be connected only if the work consists of approved materials and permission is gained from Hunter Water. The licensee shall obtain Hunter Water requirements before connecting any pre-existing system. Hunter Water shall require a test to be carried out to verify soundness of the installation. Inspection of existing work shall be conducted by NSW Fair Trading.

6.12 Stormwater Discharge to Sewer – Prohibited

You must **NOT** discharge stormwater or groundwater to Hunter Water’s sewerage system, or connect pipes carrying stormwater or groundwater to Hunter Water’s sewerage system.

7 TRADE WASTE

7.1 Introduction

If you are a non-residential customer of Hunter Water, you are bound to meet and satisfy the requirements of Hunter Water’s Trade Waste Water Policy, Standards and any additional requirements stipulated in an Agreement issued under Section 37 of the Hunter Water Act (1991) or as nominated in the Hydraulic Services Connection Requirements.

It is an offence under Section 31 of the Hunter Water Act 1991 to discharge any substance into a sewer or other works owned by Hunter Water without its prior written agreement.

Furthermore, Hunter Water’s Customer Contract, specifically states that the discharge of trade wastewater will only be allowed with the prior express written permission of Hunter Water. The written permission will take the form of an Agreement commensurate with the category of risk determined for the proposed discharge.

We may also restrict or disconnect the supply of services to your property in the following circumstances: You discharge trade wastewater into our wastewater system without a trade waste agreement with us or do not comply with the conditions of the trade waste agreement.

Note: Trade waste facility installation, alteration and design parameters are NOT defined or regulated under the Plumbing and Drainage Act 2011. Therefore installation and maintenance of property Trade Waste facilities shall be regulated by the Network Utility Operator (Hunter Water).

Hunter Water specifies the installation and maintenance responsibilities regarding trade waste facility installation in Hunter Water Regulation 2015, current Hunter Water Customer Contract, Trade Waste Water Policy and related Standards and the following requirements.

7.2 Liquid Trade Waste

- All work of sanitary plumbing and sanitary drainage associated with trade waste shall be carried out in accordance with the provisions of Hunter Water’s Trade Wastewater Standards.
- All Trade Waste fixtures and products shall be authorised by Hunter Water. Hunter Water may require specific materials, pre-treatment facilities and design technology in relation to the type of wastewater discharge and the effects on Hunter Water’s systems.

Note: Above ground oily water separators are only allowed for installation in Hunter Water’s area of operations – below ground oily water separators/traps are not allowed for new installation.

- Biological or other residuals from sewerage management facilities, grey water diversion devices or water treatment systems shall not be returned to the sewerage system without prior approval by Hunter Water. Hunter Water may set limits as to the rate of flow and discharge characteristics entering the sewerage system

7.3 Arrestors and Special Pits

An application to install an arrestor or special pit shall include:

- Design
- Type
- Size
- Material composition
- A Trade Waste Water application for permission to discharge to Hunter Water's sewer main
- Site Containment Backflow Prevention Device(s) to protect the water supply
- Any other information that may be required by Hunter Water specific to the development

7.4 Trade Waste Metering

Hunter Water may require a metering device to be installed to monitor the wastewater discharge volume from a premise. All costs associated with purchasing, installing, operating and maintaining flow meters will be the responsibility of the property owner. The metering device is to be located in a safe, accessible location and be maintained in good working order. It is the responsibility of the owner to ensure that the flow meter:

- Is a type and model specified by Hunter Water
- Continually records the rate of flow of trade waste water
- Incorporates a cumulative totaliser, calibrated to record in kilolitres, which cannot be reset to zero
- Is calibrated initially and annually by an accredited company. The owner must also supply to Hunter Water a copy of each trade waste flow meter calibration certificate annually
- Provide a permanent power source for the control panel of the meter and pay the relevant power usage charges. A battery back-up may be required in a meter to continue flow recording in the event of a power failure

Additional References: See the Relevant Hunter Water Trade Waste Policy.

7.5 Requirements to install a Reflux Valve

All trade waste pre-treatment facilities such as grease arrestors, silt arrestors, dilution pits installed below ground shall be fitted with an approved reflux valve at the outlet of the Trade Waste facility to prevent the overflow of sewage into the facility.

7.6 Location and Installation of Trade Waste Facilities

All trade waste pre-treatment facilities shall be located and installed so that:

- They are protected from vehicular damage
- They do not allow ingress of stormwater into the sewerage system
- They allow safe access for inspection, sampling and maintenance
- They comply with manufacturers specifications

Note: Predominantly Trade Waste pre-treatment facilities are located externally. Should this not be possible, local council and Hunter Water have specific requirements for installation of trade waste facilities internal of buildings which must be met to ensure health and safety compliance. Contact with local council and Hunter Water must be made to confirm these requirements prior to any installation works.

7.7 Trade Waste – Sewer Inspection Shaft

Hunter Water may require new developments discharging trade wastewater to Hunter Water's sewerage system to incorporate a 150mm boundary trap sewer inspection shaft. Hunter Water should be consulted prior to the connection of the sewer service for confirmation.

7.8 Trade Waste – Maintenance Responsibilities

The property owner is responsible to carry out pre-scheduled maintenance to the trade waste facilities. Hunter Water requires a **management plan** outlining the maintenance program and responsible persons. The property owner is responsible to maintain an on-site record of cleaning procedures and maintenance activities.

8 ADMINISTRATION

The administration as detailed in the Sewer Connections Standard describes the requirements of how to apply for connection or disconnection to the sewerage infrastructure.

After an application has been reviewed and accepted by Hunter Water, the connecting to services will be deemed authorised. The authorisation is subject to the condition to the Services Connection Standard and the Customer Contract and Hunter Water's Regulation 2015.







8.1 Connecting to Hunter Water's Services

If you are building a home, renovating, developing or subdividing land you will need to know how to connect and/or disconnect from Hunter Water's wastewater services and in some instances stormwater.

Your wastewater services will generally be connected and ready to use if you are moving into an established house and you should not be required to complete the connection /disconnection process.

The information below outlines Hunter Water's basic steps to connect or disconnect. Prior to connecting or disconnecting you will need to submit an application and pay the relevant fees.

8.1.1 How do I apply to connect or disconnect from Hunter Water's Services?

 <p>Step 1</p>	<p>Have Hunter Water check your building plans to make sure they don't impact Hunter Water's assets.</p>		
 <p>Step 2</p>	<p>Apply for relevant Development Applications with Hunter Water if required. Please refer to the "Land Development Manual" on Hunter Water's website for further details.</p>		
 <p>Step 3</p>	<p>Apply to the relevant consent authority for development approval if needed i.e. Council, Mine Subsidence, etc.</p>		
 <p>Step 4</p>	<p>Pay your connection Fees and Water and Wastewater</p>	<p>→</p>	<p>For anything more than a stand-alone house you may be required to engage a hydraulic consultant and submit a hydraulic assessment.</p>
 <p>Step 5</p>	<p>Apply to Hunter Water for connections and/or disconnections. This can only proceed once the relevant approvals have been granted (Applications and inspections to be submitted and booked a minimum of two working days prior to works).</p>		
 <p>Step 6</p>	<p>A licensed plumber makes the connections.</p>		
 <p>Step 7</p>	<p>Have your plumbing inspected: Contact NSW Fair Trading for wastewater connections. Contact Hunter Water on 1300 675 000 for water connections.</p>		

8.1.2 How do I find out what services are available to my property?

Before you proceed with your development or apply to connect to Hunter Water's services you should enquire about what services are available to your property. Wastewater services are not available to all properties.

Properties may be connected by different types of wastewater services (gravity or pressure sewer etc.) therefore prior to having your building plans drawn up or planning your connections, Hunter Water recommends you investigate what kind of services are available.

In Hunter Water’s area of operation you can find out what services are available for your property before you apply to connect or proceed with any development by:

Term	Definition
Sewer Location Diagram	This diagram shows the connection point of the wastewater pipes to your property. These are usually attached to your property sale contract provided by your conveyance or solicitor. A sewer location diagram can be purchased from Hunter Water.
Dial Before You Dig	You should check the location of Hunter Water’s services if you are doing any development work on your property so our services are not damaged. Dial Before You Dig will provide a plan of Hunter Water’s services that are on or near your property for no fee by calling 1100.
Service Location Diagram	This diagram shows where water and wastewater services are located in relation to a property’s boundary. These diagrams can be purchased from Hunter Water.
Ask Hunter Water	Call Hunter Water’s Contact Centre on 1300 657 657.

8.1.3 How do I connect or disconnect from Hunter Water’s wastewater services?

Hunter Water requires an application to be submitted and relevant fees paid before you connect or disconnect from Hunter Water’s services. If you want to connect any development other than a stand-alone house you will need to have the relevant certificates, letters and approvals prior to submitting your connection / disconnection application. Approvals you may require include a Section 50 Certificate or Hydraulics Assessment. Please refer to the “Land Development Manual” on Hunter Water’s website for more details. All requirements need to be met before submitting connection applications.

To connect you will need to complete the Services Application Form by providing the following details:

- The address of the property to be connected including the LOT and DP Number.
- The name and address, phone number and email address of both the applicant and the property owner
- The plumbers name, phone number and License details
- The date of the inspection (this indicates the connection work is complete)
- Applications for connection and inspections submitted and booked a minimum of two working days prior to works

Note: Hunter Water requires the application for connection of water and wastewater services to be completed and submitted simultaneously (there is a twenty-two week exemption form sewer discharge fees).

To disconnect you will need to complete the Services Application Form by providing the following details:

- Remove and return the meter if no longer required. Refer to “NOTE” below.
- The address of the property to be disconnected including LOT and DP Number
- The name and address, phone number and email address of both the applicant and the property owner
- The plumbers name, phone number and License details
- The date of the sewer disconnection inspection (this indicates complete of the work)

9 DEFINITIONS, ACRONYMS AND ABBREVIATIONS

Term	Definition
CEP	Common Effluent Pump System
COAG	NSW State Government and Coalition of Australia Governments
Corporation	Hunter Water Corporation
Defective and Unauthorised Work	Any sewer service on the property that through construction or use of the service does not comply with current codes of practice, standards, legislation or regulations. Can also include leakage from the service.
Electrolysis Corrosion	Corrosion produced by the contact of two dissimilar metals in the presence of an electrolyte.
EPA	Department of Environmental Protection Authority
HWC	Hunter Water Corporation
HWPSS	Hunter Water Pressure Sewerage System
IPART	Independent Pricing Authority Regulatory Tribunal
ISPS	Individual Sewerage Pumping System
Maintenance	Includes repairs and replacement, and where relevant testing and inspections.
Non-Standard Connection	Non-standard sewer connection applies where customers do not have a sewer point of connection within their property boundaries. (Non-standard connections require the property owner to enter into a separate written agreement with Hunter Water).
Operating Licence	Licence granted to Hunter Water under Section 12 of the Hunter Water Act 1991.
Owner	A person who holds ownership title to the property, as defined by the Hunter Water Act 1991.
PPSS	Private Pressure Sewerage System
Property	An individual, dwelling, or premises used for any purpose; or Land, whether built or not (excluding public land); or A lot in a strata plan that is registered under the Strata Schemes (Freehold Development) Act 1973 or the Strata Schemes (Leaseholder Development) Act 1986 that is connected to, or for which a connection is available, to Hunter Water's water supply system or wastewater system.
WSAA	Water Services Association of Australia

10 APPENDIX DOCUMENTS

See List below.

Annexure	Description
Annexure 1	CEP Technical Specifications
Annexure 2	Sewer Metering Technical Specifications for Annexure
Annexure 3	Typical Low Pressure Technical Specification
Annexure 4	SCP-310 Service Connection Standard - Typical Boundary Kit Detail
Annexure 5	SCP-311 Service Connection Standard – Typical (HWPSS) Detail
Annexure 6	SCP-317 Service Connection Standard – Typical Vacuum Sewer System
Annexure 7	TSS-001 Service Connection Standard – Typical Common Effluent Pump System (CEP)
Annexure 8	TSS-002 Service Connection Standard – Typical Private Pressure Sewerage System (PPSS)
Annexure 9	TSS-003 Service Connection Standard – Sewer Connection Detail
Annexure 10	TSS-004 Service Connection Standard – Sewer Disconnection Detail
Annexure 11	TSS-005 Service Connection Standard – Non-Boundary Trap – Residential
Annexure 12	TSS-006 Service Connection Standard – Boundary Trap Sewer Shaft – Residential
Annexure 13	TSS-007 Service Connection Standard – Swimming Pool Backwash Discharge Detail

